

- LEGEND**
- PROPOSED ASPHALT
 - PROPOSED CONCRETE
 - BUILDING SETBACK
 - EXISTING EASEMENT
 - PROPERTY BOUNDARY
 - NEIGHBORING LOT LINE
 - PROPOSED SEWER SERVICE
 - PROPOSED WATER SERVICE
 - PROPOSED FIRE HYDRANT
 - PROPOSED STREET LIGHT
 - PROPOSED STADIUM LIGHT
 - LIMITS OF CONSTRUCTION

- FLOOD ZONE LEGEND**
- APPROXIMATE LOCATION OF FLOODWAY
 - APPROXIMATE LOCATION OF FEMA-MAPPED SPECIAL FLOOD HAZARD AREA, ZONE AE
 - APPROXIMATE LOCATION OF 0.2% ANNUAL CHANCE FLOOD HAZARD AREA, ZONE X SHADED

- LANDSCAPING NOTES**
- ALL TREES SHALL BE PROVIDED AS CONTAINER GROWN TREES.
 - PROPERTY OWNER SHALL BE RESPONSIBLE FOR MAINTENANCE AND PRESERVATION OF ALL LANDSCAPING.
 - PLANT MATERIAL SHOWN HERE IS REPRESENTED AT ITS MATURE SIZE. PLANTS TO BE INSTALLED WILL BE SIGNIFICANTLY SMALLER THAN THOSE SHOWN.
 - CONTRACTOR TO SEED ALL DISTURBED AREA LEFT UNPAVED AND GUARANTEE COVERAGE OF VEGETATION UNTIL ESTABLISHMENT OF GRASS. GRASS TYPE SHALL BE BERMUDA GRASS.
 - ALL LANDSCAPING SHALL BE SERVED BY AUTOMATIC IRRIGATION SYSTEM.
 - THE REPLACEMENT OF DEAD LANDSCAPING MUST OCCUR WITHIN 90 DAYS OF NOTIFICATION. REPLACEMENT MATERIAL MUST BE OF SIMILAR CHARACTER AS THE DEAD LANDSCAPING.
 - ALL TREES MUST BE AT LEAST SIX (6) FEET TALL.
 - LANDSCAPING SHOWN IS CONCEPTUAL AND SUBJECT TO CHANGE.

SYMBOL	SIZE	NAME	#	SF VALUE	TOTAL
(Symbol)	>3" CAL.	LIVE OAK (QUERCUS VIRGINIANA)	16	250	4000
(Symbol)	1.5"-3.0" CAL.	CREPE MYRTLE (LAGERSTROMIA INDICA)	13	100	1300
(Symbol)	2-5 GAL.	INDIAN HAWTHORN (RHAPHIOLEPIS INDICA)	80	10	800
(Symbol)		HYDROSEED (BERMUDA)			

LANDSCAPING ANALYSIS

CONSTRUCTION ACTIVITIES:

- PARKING + PAVEMENT = 26,700 SF
- BUILDING + PATIOS = 20,100 SF
- NET TOTAL = 46,800 SF

REQUIRED LANDSCAPING:

15% OF DEVELOPED AREA SHALL BE LANDSCAPED
 46,800 SF X 15% = 7,020 SF REQUIRED

50% LANDSCAPE AREA SHALL HAVE TREES
 7,020 SF X 50% = 3,510 SF REQUIRED

PROVIDED LANDSCAPING:

- 16 CANOPY TREES @ 250 SF = 4,000 SF
- 13 NON-CANOPY TREES @ 150 SF = 1,950 SF
- 80 SHRUBS @ 10 SF = 800 SF
- GRASS COVERAGE (15% MAX. ALLOWED) = 1,000 SF
- TOTAL PROVIDED = 7,750 SF

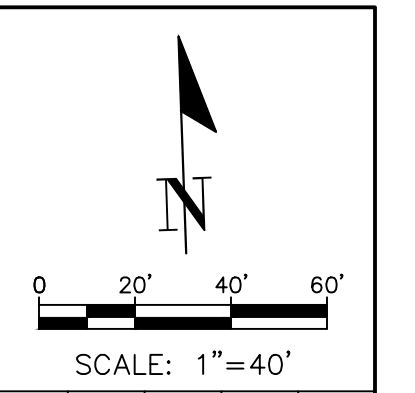
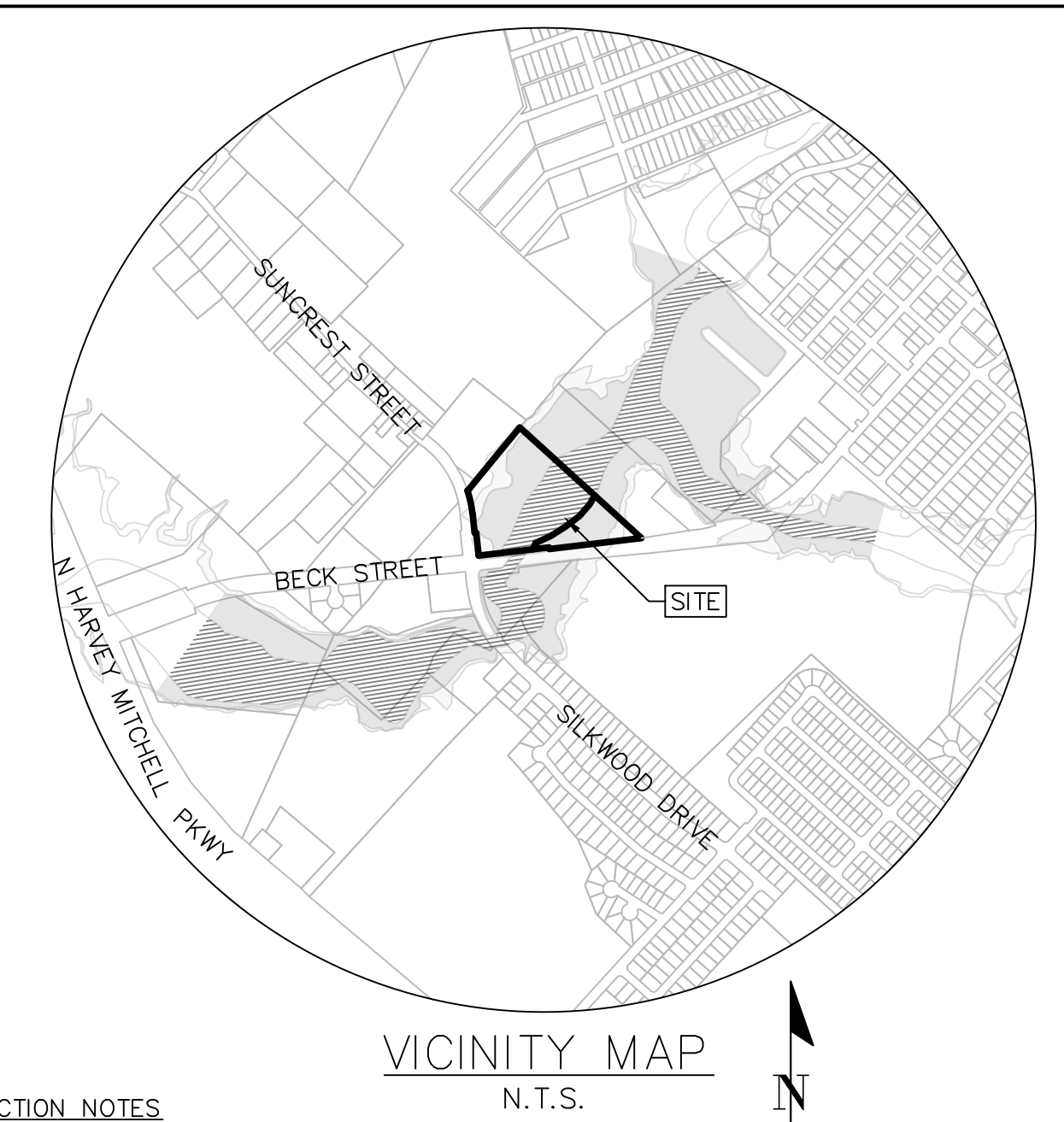

DATE	REVISION	NO.

OWNER INFORMATION

LEOBARDO TEUTLE FLORES
 1008 WELLINGTON AVE
 BRYAN, TX 77803
 (979) 739-0035

PROPERTY INFORMATION

PUEBLA SOCCER COMPLEX
 BLOCK 1 LOT 1
 8.221 ACRES

- CONSTRUCTION NOTES**
- ALL CONSTRUCTION SHALL BE IN ACCORDANCE WITH THE LATEST CITY OF BRYAN STANDARD SPECIFICATIONS AND DETAILS. ALL CONSTRUCTION SHALL BE COORDINATED WITH THE CITY ENGINEER'S OFFICE.
 - CONTRACTOR TO OBTAIN ALL NECESSARY DEVELOPMENT AND CONSTRUCTION PERMITS AND APPROVALS AT THEIR OWN EXPENSE PRIOR TO COMMENCEMENT OF WORK.
 - CONTRACTOR SHALL ARRANGE FOR REQUIRED CITY INSPECTIONS.
 - ALL MATERIALS AND EQUIPMENT SHALL BE BOTH FURNISHED AND INSTALLED UNLESS OTHERWISE NOTED.
 - PROPOSED PARKING SHALL BE A MINIMUM OF 1.5" OF ASPHALT PAVEMENT ON TOP OF 6" OF LIMESTONE BASE WITH CURB.
 - ALL CONCRETE TO BE CONSTRUCTED WITH 4,000 PSI (MINIMUM) 28-DAY STRENGTH PORTLAND CEMENT CONCRETE.
 - CONTRACTOR TO REMOVE ALL ITEMS DURING CLEARING AND GRUBBING. REMOVE NOT ONLY THE ABOVE GROUND ELEMENTS, BUT ALL UNDERGROUND ELEMENTS AS WELL. ALL EXCAVATED MATERIAL SHALL BECOME THE PROPERTY OF THE CONTRACTOR UNLESS OTHERWISE DIRECTED BY THE OWNER. ALL DEBRIS MUST BE LEGALLY DISPOSED OF OFFSITE.
 - CONTRACTOR TO PROTECT ALL EXISTING TREES OUTSIDE OF GRADING LIMITS AND ANY CALLED OUT TO BE PROTECTED WITHIN GRADING LIMITS. ALL FENCES, STRUCTURES, AND UTILITIES SHALL BE PROTECTED.
 - PRIOR TO GRADING OPERATIONS, CONTRACTOR IS TO STRIP THE FIRST 6" OF SOIL. CONTRACTOR SHALL PROOF ROLL THE ENTIRE SITE AND REMOVE ANY UNSTABLE MATERIALS ACCORDING TO TxDOT SPECIFICATIONS. SELECT FILL IS TO BE USED IN REPLACING OBJECTIONABLE MATERIAL.
 - ASSURE POSITIVE DRAINAGE ACROSS PROJECT SITE TO STORM WATER STRUCTURES.
 - POTABLE WATER PROTECTION: ALL DEVICES, APPURTENANCES, APPLIANCES, AND APPARATUS INTENDED TO SERVE SOME SPECIAL FUNCTION AND THAT CONNECT TO THE WATER SUPPLY SYSTEM SHALL BE PROVIDED WITH PROTECTION AGAINST BACK FLOW AND CONTAMINATION OF THE WATER SUPPLY.
 - UTILITIES PRESENTED ON THESE DRAWINGS ARE SHOWN BASED ON THE BEST AVAILABLE INFORMATION. THE CONTRACTOR SHALL BE RESPONSIBLE FOR VERIFYING THE EXACT LOCATION AND SIZE OF ALL EXISTING UTILITIES. THE CONTRACTOR SHALL NOTIFY UTILITY COMPANIES 48 HOURS IN ADVANCE OF CONSTRUCTION.
- CITY OF BRYAN: 979-209-5900
 TEXAS ONE CALL: 800-245-4545
 TEXAS 811: 800-344-8377
 ATMOS ENERGY: 979-774-2506
 SUDDENLINK COMMUNICATIONS: 979-846-2229
 WATER/SEWER CITY OF BRYAN: 979-209-5900
 BRYAN TEXAS UTILITIES (BTU): 979-821-5700

- SITE SPECIFIC NOTES**
- CURRENT OWNER OF THE PROPERTY: LEOBARDO TEUTLE FLORES
 - CURRENT ZONING: RETAIL C-2, APPROVED BY CITY COUNCIL ON 4/9/2024, ORDINANCE NO. 2024-001
 - TOTAL LOT ACREAGE: 8.221 ACRES
 - CONTOURS SHOWN ARE FROM FIELD SURVEY DATA.
 - THIS TRACT LIES WITHIN FLOOD ZONE 'X' UNSHADED, 'X' SHADED, 'AE' AND DOES PARTIALLY LIE WITHIN A SPECIAL FLOOD HAZARD AREA SUBJECT TO THE 1% ANNUAL CHANCE FLOOD (100-YEAR FLOODPLAIN) ACCORDING TO THE BRAZOS COUNTY FLOOD INSURANCE RATE MAP (FIRM) PANEL NO. 48041C0195E, REVISED TO REFLECT LOMR 12-06-1839P, EFFECTIVE 5/18/2012.
 - DEVELOPER TO SUBMIT ELECTRICAL LOAD INFORMATION WHEN REQUESTING ELECTRICAL SERVICE FROM BTU AT 979-821-5770 120 DAYS BEFORE POWER IS NEEDED.
 - WHERE ELECTRIC FACILITIES ARE INSTALLED, BTU HAS THE RIGHT TO INSTALL, OPERATE, RELOCATE, CONSTRUCT, RECONSTRUCT, ADD TO, MAINTAIN, INSPECT, PATROL, ENLARGE, REPAIR, REMOVE AND REPLACE SAID FACILITIES UPON, OVER, UNDER, AND ACROSS THE PROPERTY INCLUDED IN THE PUE, AND THE RIGHT OF INGRESS AND EGRESS ON PROPERTY ADJACENT TO THE PUE TO ACCESS ELECTRIC FACILITIES.

PARKING ANALYSIS

PROPOSED IMPROVEMENTS:
 11,840 SF INDOOR SOCCER FACILITY (W/ OUTDOOR SOCCER FIELDS)

NEW REQUIRED PARKING:
 1 SPACE PER 250 SF DEVELOPED AREA
 48 TOTAL REQUIRED

NEW PROVIDED PARKING:
 48 STRAIGHT IN PARKING
 2 ADA PARKING W/ VAN ACCESSIBLE
 50 TOTAL PROVIDED

PUEBLA SOCCER COMPLEX
 SITE PLAN

ENGINEER INFORMATION

CENTER POLE ENGINEERING
 4816 KNIGHT DR
 BRYAN, TX 77802
 (713) 564-8105
 TBPFLS F-23601

PROJECT NO.	DATE	DESIGNED BY	DRAWN BY	CHECKED BY
2306	04/08/2024	TJJ	TJJ	PRJ

PRELIMINARY
 THIS DRAWING IS FOR INFORMATION PURPOSES ONLY. IT IS NOT TO BE USED FOR CONSTRUCTION, BIDDING, OR PERMITTING.

SHEET NUMBER
 C5



!!! CAUTION !!!
 DEPTH AND LOCATION OF EXISTING UTILITIES ARE APPROXIMATE AND MUST BE FIELD VERIFIED BY CONTRACTOR BEFORE EXCAVATING IN THE AREA.